

Note : Fixed position

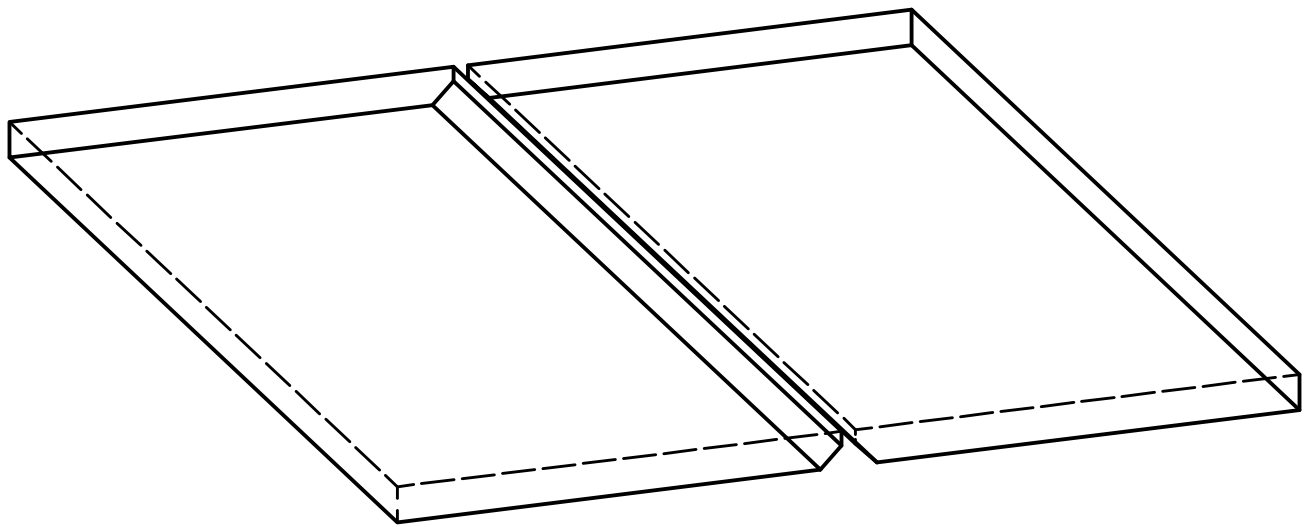

Bahan : Pelat baja lunak (A 36)  
 Ukuran : 300 x 125 x 10 mm (MMAW), 2 buah  
 350 x 125 x 12 mm (GMAW), 2 buah  
 Elektroda : (AWS) E 7016/7018, Ø2,6 & 3,2 mm  
 (AWS) ER 70S-G, Ø1,2 mm

V - BUTT JOINT 4G/PE POSITION	Skala	Digambar	I Kadek Dwi Permana Putra	
	Unit : mm	Diperiksa	Drs. I Nyoman Gede Suyasa	
		Disetujui	Ida Bagus Putu Wiratjaya ST.	
LKS PROVINSI BALI 2010	MANUAL METAL ARC WELDING AND GAS METAL ARC WELDING		No. 4	A4