

Note : Fixed position

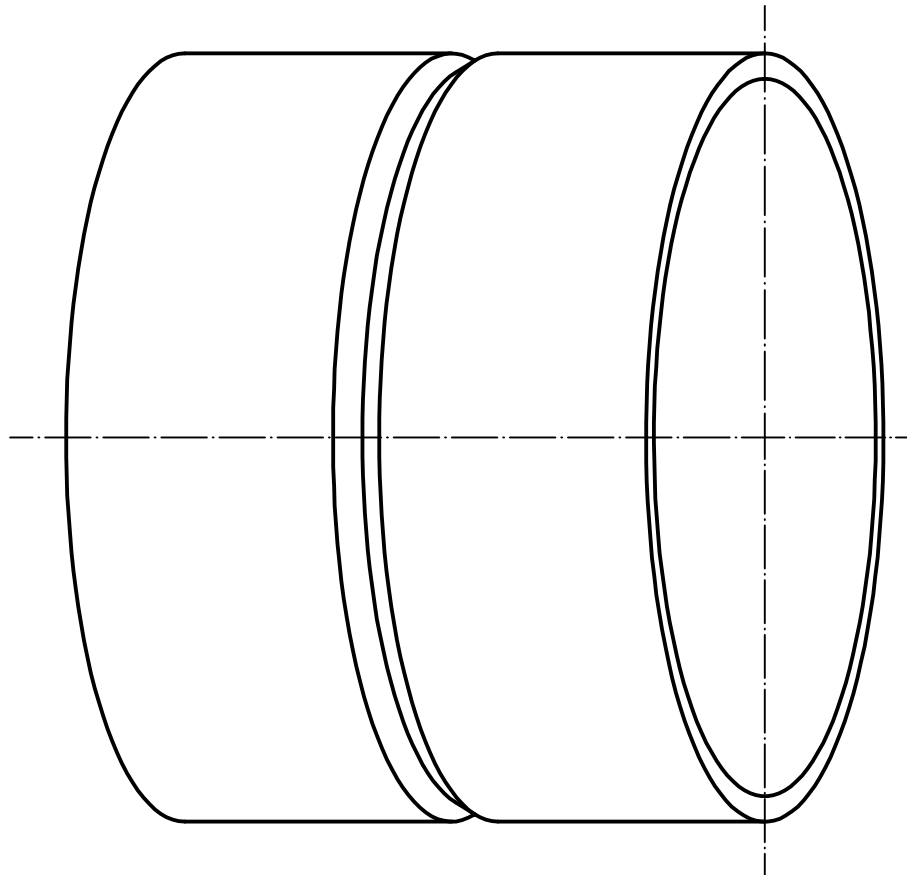

Bahan : Scedule stell pipe (A 36)
 Ukuran : Ø4" x 120mm x Sch 40. Qty : 2 buah
 Elektroda : (AWS) E 7016/7018, Ø2,6 & 3,2 mm

V - BUTT JOINT 1G/PA or 5G/PF/PG POSITION	Skala	Digambar	I Kadek Dwi Permana Putra	
	Unit : mm	Diperiksa	Drs. I Gede Nyoman Suyasa	
		Disetujui	Ida Bagus Putu Wiratjaya ST.	
LKS PROVINSI BALI 2010	MANUAL METAL ARC WELDING		No. 2	A4